

NOTES:

1. Exterior material - SS 316L
2. Surface roughness Ra 1.6 µm or better
3. Weld line may protrude or be visible near mid-line of XBOT
4. Custom mounting holes sizes and positions available upon request

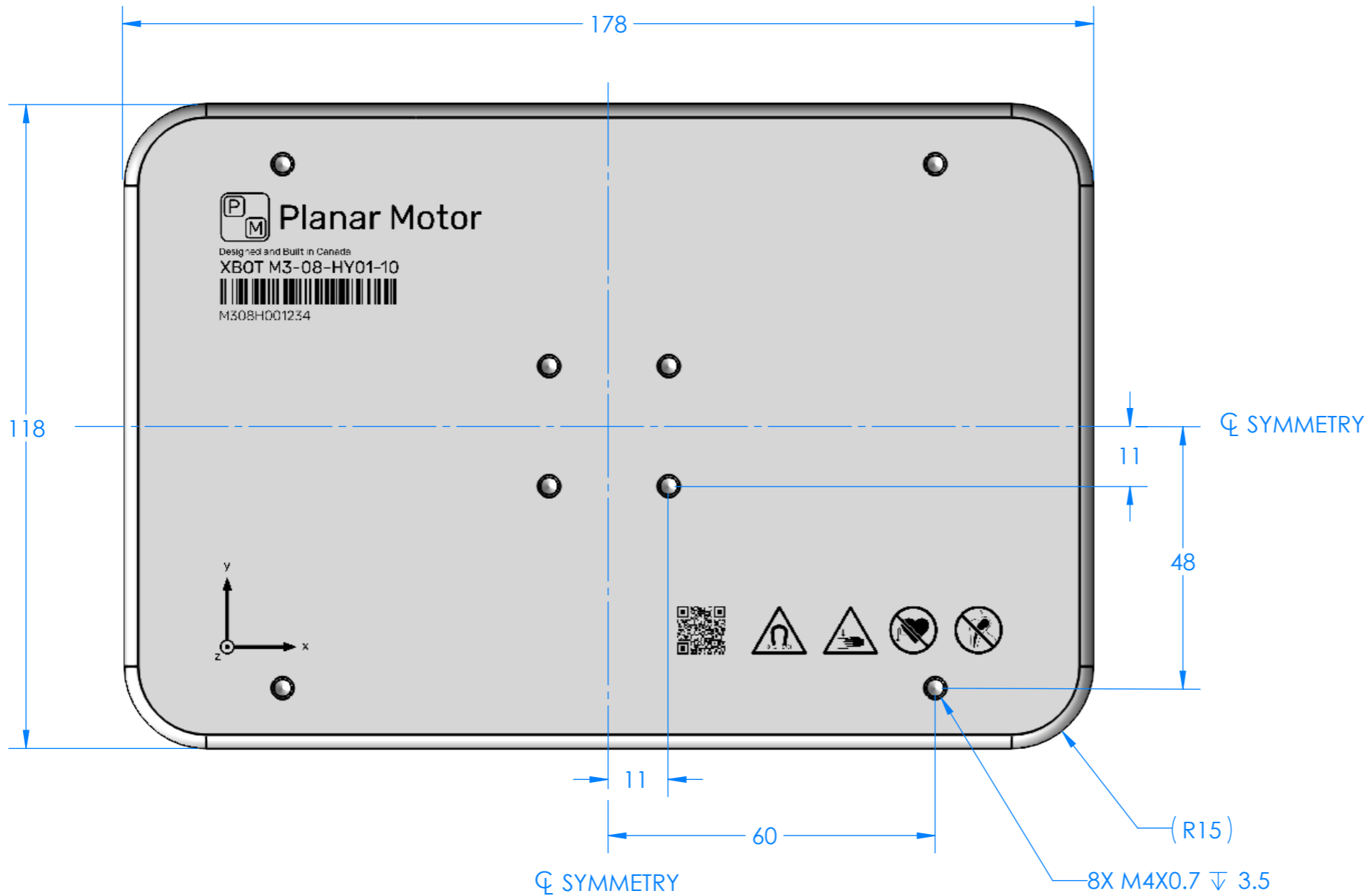

<p>PRODUCT DRAWING</p>		Dimensions and tolerances per ASME Y14.5M-1994 Surface texture per ANSI/ASME B46 1-1985			
		Product dimensions subject to change			
Model XBOT M3-08-HY01-10, HYGIENIC		Dwg. No. M3-08-HY01-10-OEM		Rev. 0.1	
Planar Motor Incorporated - Vancouver, Canada					
Issue Date 2026/05/12		Projection 	Dimension mm	Size A3	Scale 1:1
Sheet 1/1					